

Connection Instructions for Communication with SATEC Instruments

All SATEC Powermeter models today are equipped with one or two optically isolated serial communication ports. This allows work in various types of communication networks, including those with high voltage disturbances and magnetic fields.

The communication port supports EIA RS-232, RS-422 or 485 standard interfaces (user or manufacturer selectable), allowing connection to a computer, PLC or modem. **Table 1** presents a complete list of communication parameters for all SATEC instruments.

The communications works on a Master-Slave basis, where the host computer is the master and the instrument is the slave, i.e., the computer transmits requests to the instrument which responds to the computer, but the instrument does not transmit information on its own initiative. The host computer polls the instrument in order to receive measurement data, or to read or program the Powermeter configuration parameters.

Multi-drop Connections

SATEC instruments may be used in multi-drop networks. Instruments are connected to this network via RS-422 and RS-485 communication ports. Both ports are serial differential interface standards. Because of the differential mode used, network noise is almost nullified.

In the RS-422 standard, the instruments connect to a network via two pairs of wires, one pair for transmission, and one for reception (full duplex).

In the RS-485 standard, instruments are connected to a network via one pair of wires. The same pair is used both for transmission and reception (half duplex), i.e. instrument transmitter and receiver are connected in parallel.

The network is connected to a local host computer (or PLC) communication port (RS-422 or RS-485), or to an RS-232 computer communication port via the SATEC RSC-232 Converter. The Converter supports up to 32 instruments and features automatic data detection (no need for external RTS). The distance between the Converter and the RS-232 device may be up to 15 meters. A remote host computer may be connected to this network via the RSC-232 Converter and two modems. The Converter and the first modem are installed together with the instruments and the second modem – with the computer.

Communication Connection

Up to 32 instruments can be connected to one multi-drop RS-422/RS-485 communication network, which consists of a shielded, twisted pair cable (for RS-485: 2 pairs, 1 active and 1 reserve; for RS-422: 3 pairs, 2 active and 1 reserve). Total cable length may be up to 1200 meters.

The cable consists of the segments between instruments. The shield of each RS-422/RS-485 cable segment must be connected to the ground at *one* end only. Ensure that the polarity is correct when connecting to the RS-422/RS-485 port (+) and (-) terminals of each instrument.

The wires of cable should be between 22 AWG and 12 AWG (0.3 to 3.3 mm²) (see **Table 1**).

It is recommended that an intermediate terminal strip be used to connect each instrument to the network, to allow for easy removal of an instrument if necessary.

Wiring Configurations

The multi-drop network must have a point-to-point configuration, i.e., the (+) and (-) terminals of each instrument must be connected to the associated terminals on the next instrument. It is recommended to use a straight-line wiring method. Any connection with a branch in the main bus should be avoided, such as star and tee methods; these will cause signal reflections that may cause interference (see **Figures 1-4**).

Each end point of the bus must be terminated with a ¼ watt resistor. These resistors reduce signal reflections which may corrupt signal data on the bus. Termination resistors are connected between the (+) and (-) terminals of the instrument at each end of the bus. (Where the RSC-232 Converter is used on a computer connection, the resistor is not applicable since it is built in to the converter.) The value of the resistor should match the line impedance of the cable being used and is typically between 200 and 500 Ohm.

Single-drop Communication Networks

One instrument can be connected to one host computer or modem RS-232 communication port.

The connection requires a shielded, twisted pair cable (3 pairs: 1 active, 1 ground and 1 reserve). The cable may be up to 15 meters in length; it may be possible to extend this distance using a lower transmission baud rate, shielded cabling or repeater.

The wires of cable should be 24 AWG (0.5 mm²)

Pinouts

Figures 5, 6 and 7 show the pinouts for RS-232, RS-422 and RS-485 connections respectively. Pinout summary tables are provided in **Tables 2, 3 and 4**.

Communication Protocols

All SATEC instruments support at least 2 protocols: ASCII and Modicon Modbus RTU. Both are open protocols that can be used by a third-party host-based software for access of all Powermeter data and configuration registers.

Many instruments support the DNP3.0 protocol as well (see **Table 1**).

Figure 1: RS-485 T-Connection

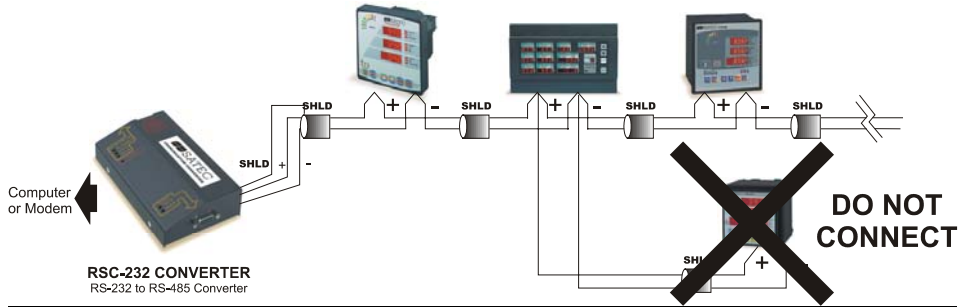

Figure 2: RS-485 Star Connection

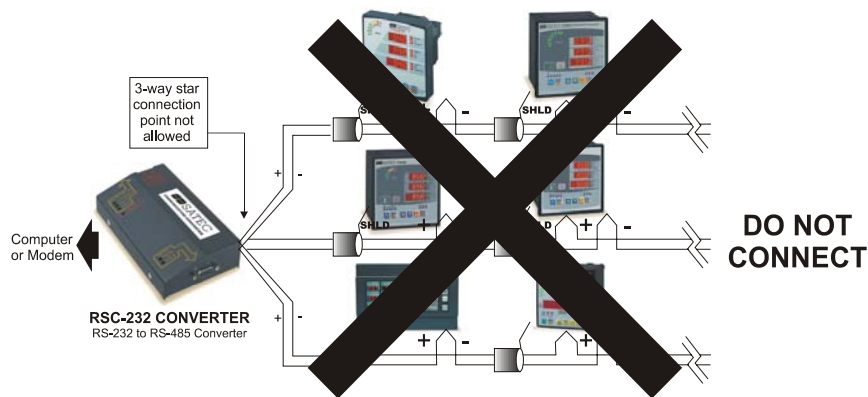

Figure 3: RS-485 Straight Line Configuration

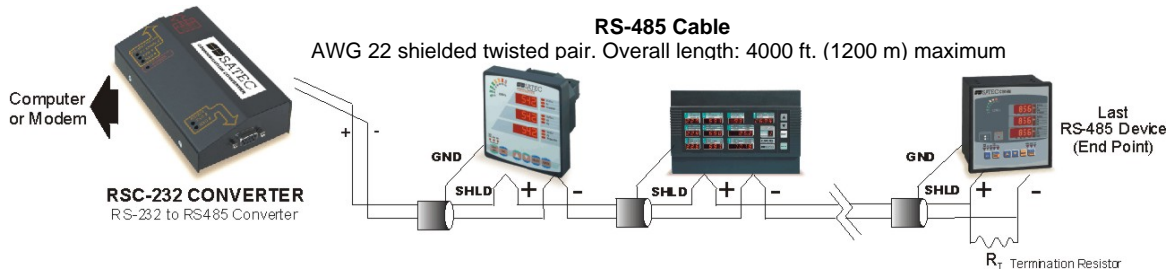
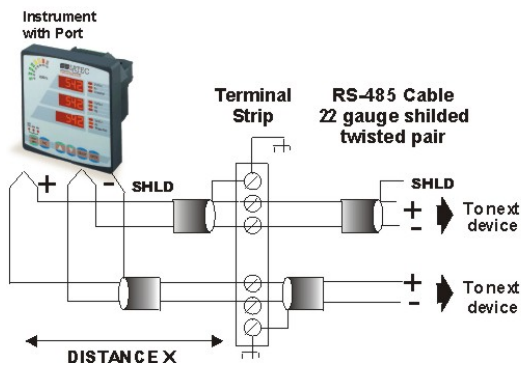

Figure 4:

CORRECT T-CONNECTION



INCORRECT T-CONNECTION

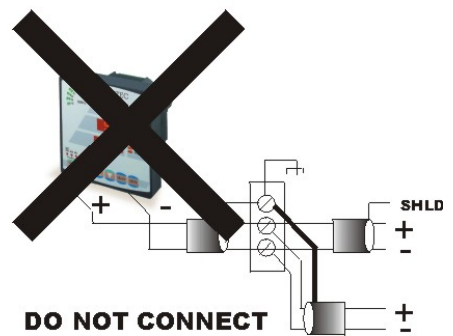

Figure 5: RS-232 Interconnection Diagram

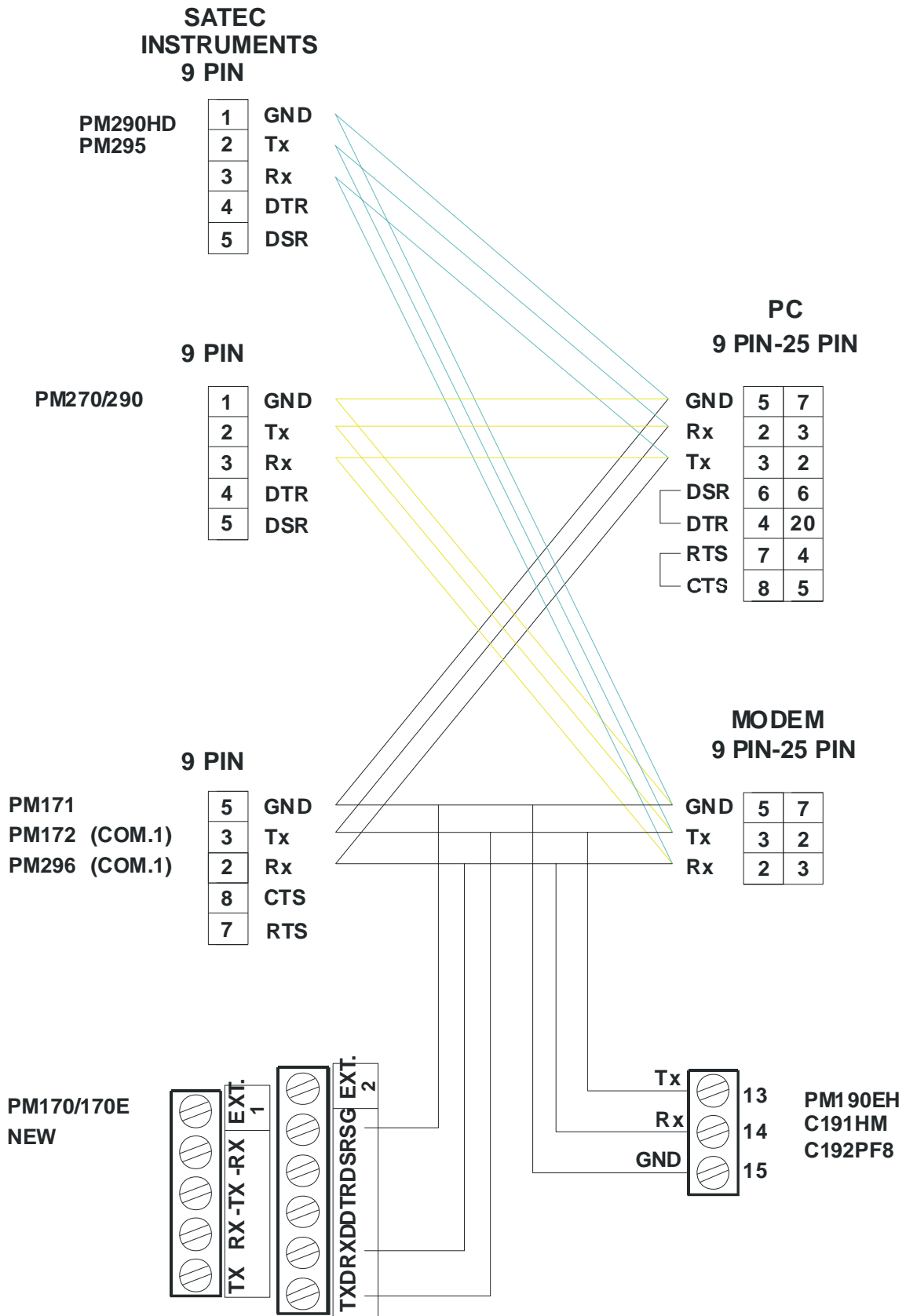
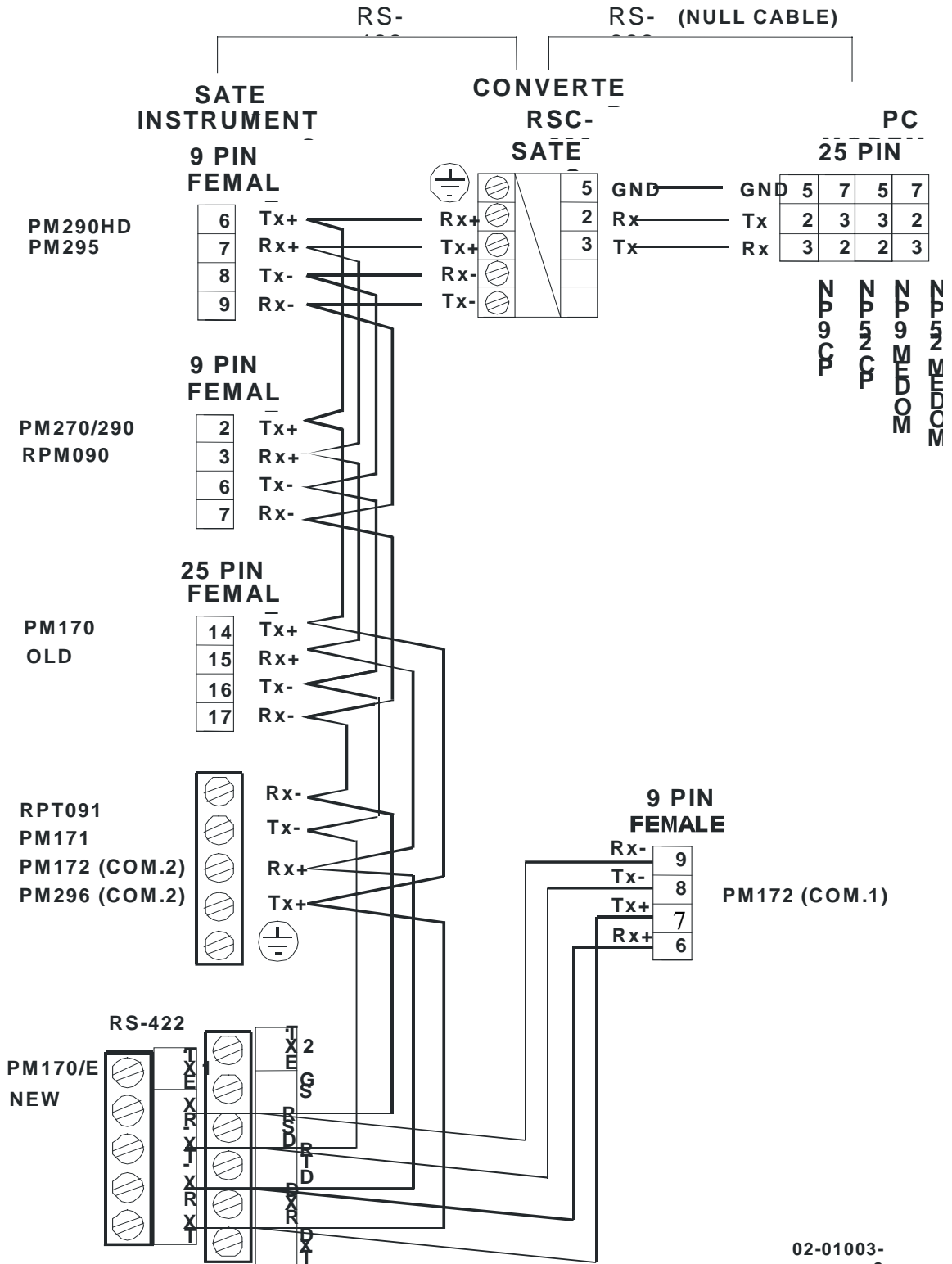
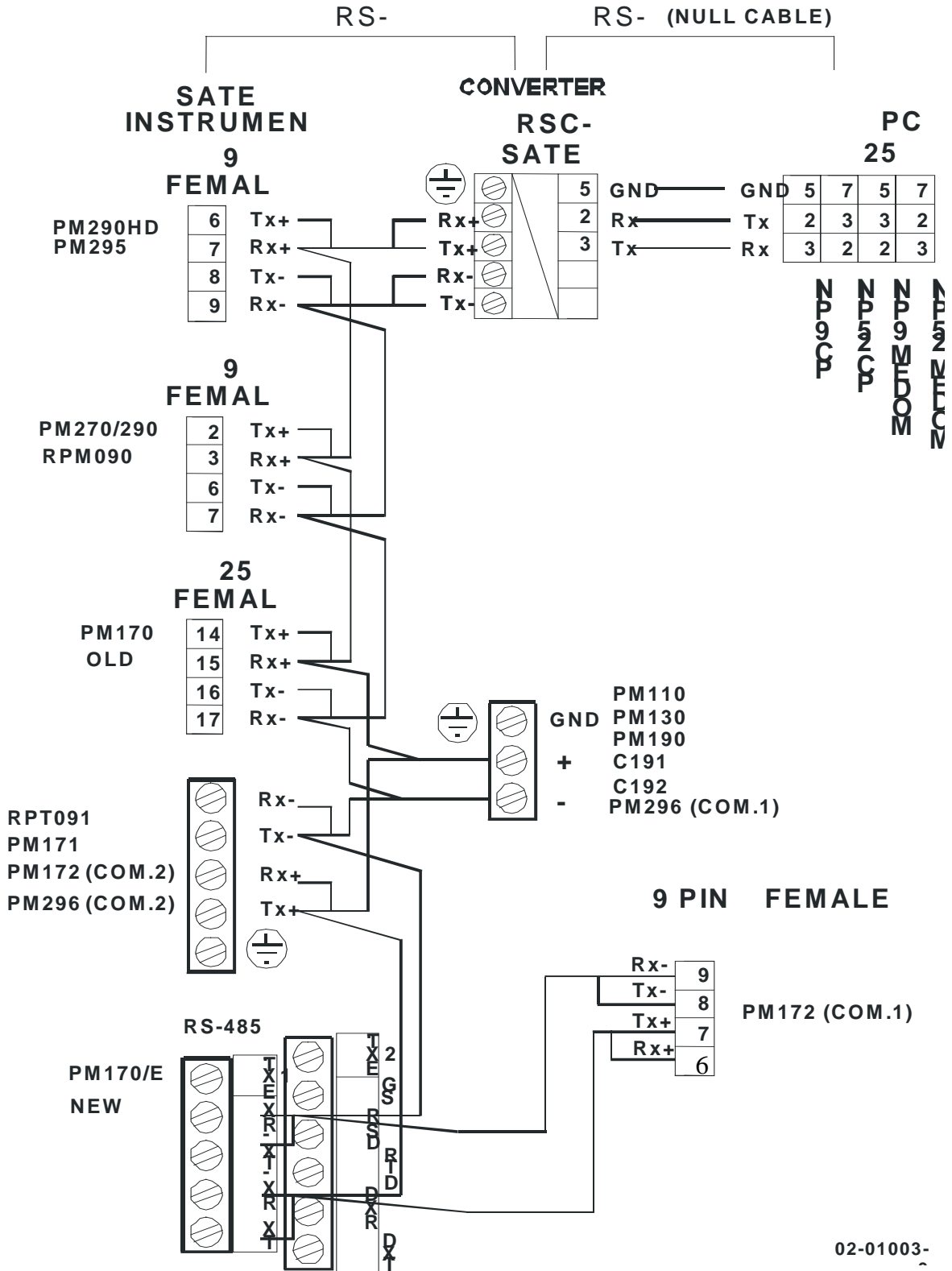

Figure 6: RS-422 Interconnection Diagram



02-01003-

Figure 7: RS-485 Interconnection Diagram



02-01003-

Table 1: Communication Parameters

| Instruments | Serial Port | Connector | Proto- cols | Max. baud rate | RS-232 | | | RS-422/ RS-485 | | | | |
|-----------------------|---|--|---------------------------|----------------------|--------|-----|-----|----------------|---------|----------|---------|------|
| | | | | | TX | RX | GND | TXD | RXD | -TXD | -RXD | GND |
| RPM 090 | RS-422/RS-485 | 9-pin female D type | ASCII Modbus | 9600 | none | | | 2 | 3 | 6 | 7 | none |
| RPT 091 | RS-422/RS-485 | Screws,14 AWG(2 mm ²) | ASCII Modbus | 19200 | none | | | +TX | +RX | -TX | -RX | GND |
| PM110 PM130 | RS-485 | Screws,14 AWG(2 mm ²) | ASCII Modbus DNP3.0 | 19200 | none | | | +(TX&RX) | | -(TX&RX) | | GND |
| PM170 (up to 1998) | RS-232 or RS-422 / RS-485 | 25-pin female D type | ASCII Modbus | 9600 | 2 | 3 | 1 | 14 | 15 | 16 | 17 | none |
| PM170 (from 1998) | RS-232 or RS-422 / RS-485 | Screws,14 AWG(2 mm ²) | ASCII Modbus | 9600 | TXD | RXD | SG | TX | RX | -TX | -RX | none |
| PM171 | RS-232 or RS-422 / RS-485 | 9-pin female D type Screws,14 AWG(2 mm ²) | ASCII Modbus DNP3.0 | 19200 | 3 | 2 | 5 | 15 | 16 | 13 | 14 | none |
| PM172 COM1 COM2 | RS-232 or RS-422 / RS-485 RS-422 / RS-485 | 9-pin female D type Screws,14 AWG(2 mm ²) | ASCII Modbus DNP3.0 | 19200 | 3 | 2 | 5 | 6 15 | 7 16 | 8 13 | 9 14 | GND |
| PM190 | RS-485 or RS-232 | Screws,14 AWG(2 mm ²) | ASCII Modbus | 19200 | 13 | 14 | 15 | 13 (+) | | 14(-) | | 15 |
| C191HM | RS-485 or RS-232 | Screws,14 AWG(2 mm ²) | ASCII Modbus | 19200 | 13 | 14 | 15 | 13 (+) | | 14(-) | | 15 |
| C192PF8 | RS-485 or RS-232 | Screws,14 AWG(2 mm ²) | ASCII Modbus | 19200 | 13 | 14 | 15 | 13 (+) | | 14(-) | | 15 |
| PM270 PM290 | RS-232 or RS-422 / RS-485 | 9-pin female D type | ASCII Modbus | 9600 | 2 | 3 | 1 | 2 | 3 | 6 | 7 | none |
| PM290HD | RS-232 or RS-422 / RS-485 | 9-pin female D type | ASCII Modbus | 9600 | 2 | 3 | 1 | 6 | 7 | 8 | 9 | none |
| PM295 | RS-232 or RS-422 / RS-485 | 9-pin female D type | ASCII Modbus | 38400 | 2 | 3 | 1 | 6 | 7 | 8 | 9 | none |

| Instruments | | Serial Port | Connector | Proto- cols | Max. baud rate | RS-232 | | | RS-422/ RS-485 | | | | |
|-------------|-----------------|---------------------|--|---------------------------|----------------------|--------|----|-----|----------------|-----|----------|------|------|
| | | | | | | TX | RX | GND | TXD | RXD | -TXD | -RXD | GND |
| PM296 | COM1 | RS-232 or RS-485 | 9-pin female D type Screws,14 AWG(2 mm ²) | ASCII Modbus DNP3.0 | 19200 | 3 | 2 | 5 | +(TX&RX) | | -(TX&RX) | | GND |
| | COM2 | RS-422/ RS-485 | Screws,14 AWG(2 mm ²) | ASCII Modbus DNP3.0 | 19200 | | | | TX | RX | -TX | -RX | GND |
| AX-8 | Power- meter | RS-422 | Screws,14 AWG(2 mm ²) | ASCII Modbus DNP3.0 | 19200 | | | | +TX | +RX | -TX | -RX | none |
| | Master | RS-422/ RS-485 | | | | | | | +TX | +RX | -TX | -RX | GND |

COMMUNICATIONS INTERCONNECTIONS Summary Tables

Table 2: RS-232 Cable Connections

| Signal | PM170 (25-pin) | PM270/ PM290 (9-pin) | PM190 | PM290HD/ PM295 (9-pin) | PM171/PM172/ PM296 (9-pin) | Printer | Modem | Modem |
|--------|-------------------|----------------------------|-------|------------------------------|----------------------------------|---------|-------|-------|
| Gnd | 1 | 1 | 15 | 1 | 5 | 7 | 7 | 5 |
| Tx | 2 | 2 | 13 | 2 | 3 | 2 | 2 | 3 |
| Rx | 3 | 3 | 14 | 3 | 2 | 3 | 3 | 2 |
| DTR | 4 | 4 | | 4 (DTR/RTS) | | | 20 | 4 |
| DSR | 5 | 5 | | 5 (DSR/CTS) | | | 6 | 6 |
| RTS | | | | | 7 | 6 | 4 | 7 |
| CTS | | | | | 8 | 5 | 5 | 8 |

Table 3: RS-422 Cable Connections

| Signal | PM170 (25-pin) | PM270/PM290 (9-pin) | PM290HD/PM295 (9-pin) | Converter (25-pin) | RS-422 Port (9 or 25 pin) |
|--------|-------------------|------------------------|--------------------------|-----------------------|--|
| Tx + | 14 | 2 | 6 | 2 | Pinout varies with manufacturer |
| Rx + | 15 | 3 | 7 | 3 | |
| Tx - | 16 | 6 | 8 | 14 | |
| Rx - | 17 | 7 | 9 | 15 | |

Table 4: RS-485 Cable Connections

| Signal | PM170 (25-pin) | PM270/PM290 (9-pin) | PM290HD/PM295 (9-pin) | Converter (25-pin) | RS-485 Port (9 or 25 pin) |
|--------|-------------------|------------------------|--------------------------|-----------------------|--|
| Tx + | 14 | 2 | 6 | 2 | Pinout varies with manufacturer |
| Rx + | 15 | 3 | 7 | 3 | |
| Tx - | 16 | 6 | 8 | 14 | |
| Rx - | 17 | 7 | 9 | 15 | |

Note: RTS/CTS and DTR/DSR requirements and pinout for printers may vary.